

HB Model pelleting and shredding system for wool and fiber.

7.5kw (10 hp) 22kw (30 hp) 33kw (40 hp)



Highlights of our HB pellet systems

Integrated control panel

For ease of use. UL/CE/CSA Certification for each applicable region



Stainless Steel hopper with enlarged opening for shredded wool and cellulose materials.

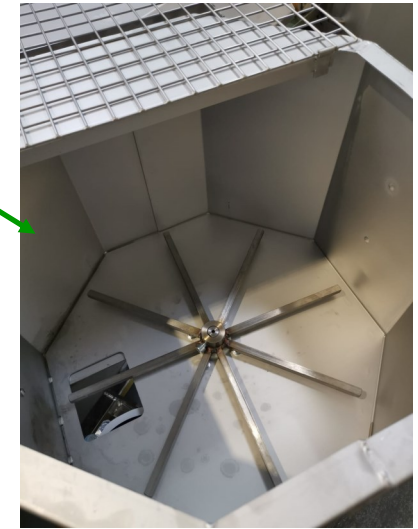

The hopper locks in place for safety & vibration reduction



Custom quick change, anti slip dies reduces down time and increases profitability. Can be made of steel or stainless steel.



All systems come with integrated water dosing pump

Mill head and rollers have premium grade bearings for long life and reduction of operating costs.

Premium quality gearboxes (Bonfiglioli) and low service factor 3 phase electric motors for years of use

Lockable industrial castors for easy portability and cleaning

Adjustable feed gate (stainless steel) for easy and precise dosing of the material to the mill head

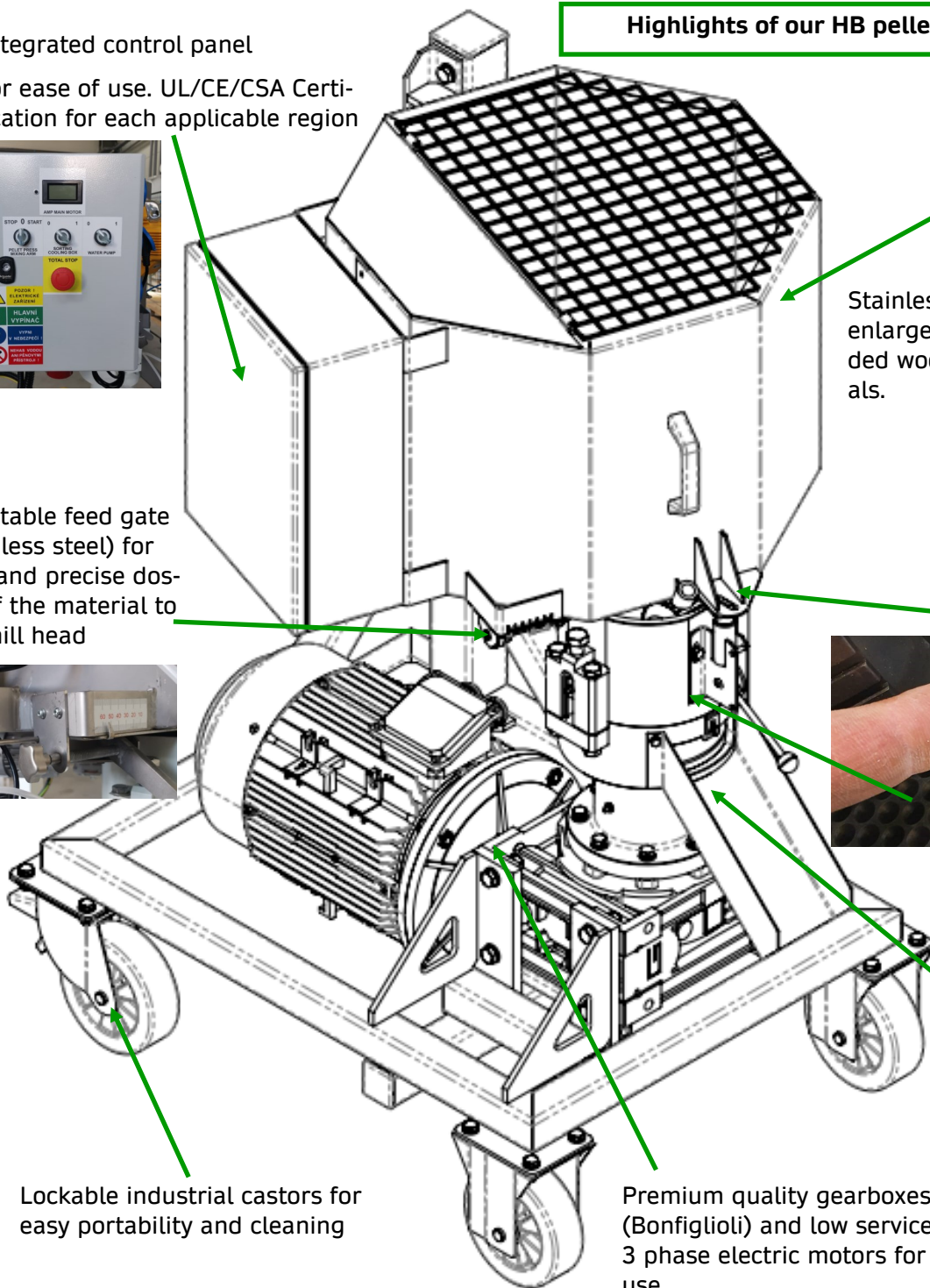

Fiber shredding with our small pellet mill line



Stainless steel vibrating pellet cleaner with plexiglass hood for operator observation 7.5kw shown removes small fibers and allows the waste to be re-pelleted

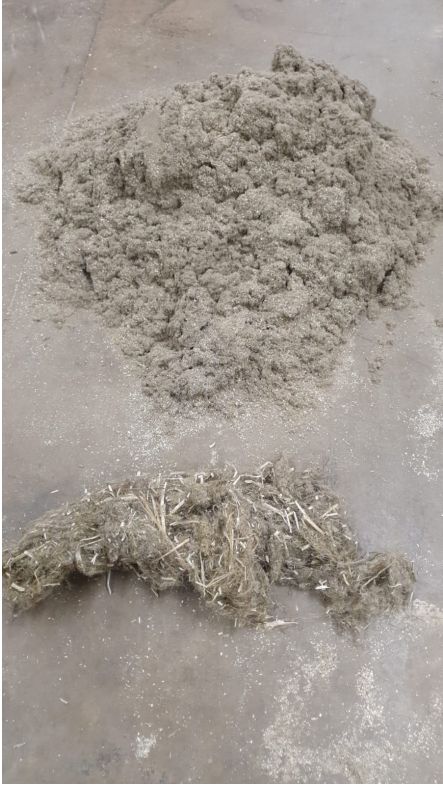

Hemp fiber before and after



Chopped sheep wool fiber to pellets



Fiber shredder for wool, bamboo, hemp stalk etc. Staggered carbide blades and easy access for cleaning.



Wool before and after the shredder

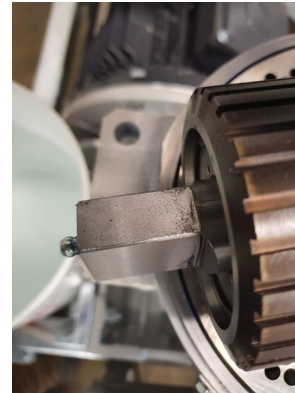
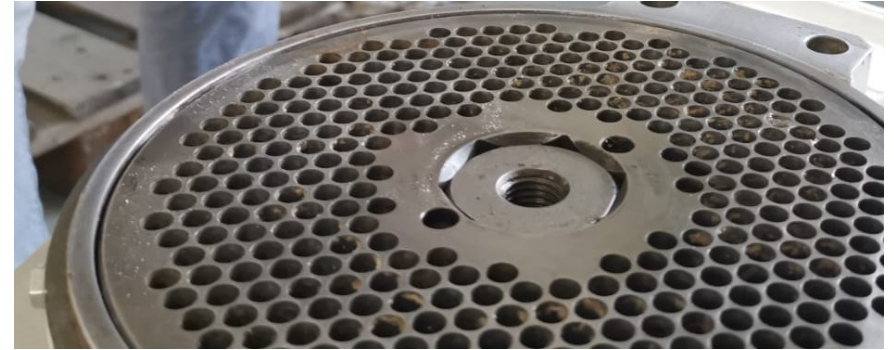

Precision engineered systems for longevity.

- * All our units come with a 2 year manufactures warranty
- * We build all the systems ourselves (factory tours available)
- * Premium CNC machined parts reduces wear and vibration
- * Built to last, long life bearings and stainless steel or galvanized frames
- * Fully stainless options available for food applications
- * Over 40 different die combinations for specific materials
- * 25 years of pelleting experience
- * Simple to operate and maintain
- * 7 days a week phone and internet support

