

HB1/HB2/HB3 Pelleting system.

7.5kw (10 hp) 22kw (30 hp) 33kw (40 hp)

Highlights of our HB pellet systems

Integrated control panel

For ease of use. UL/CE/CSA Certification for each applicable region

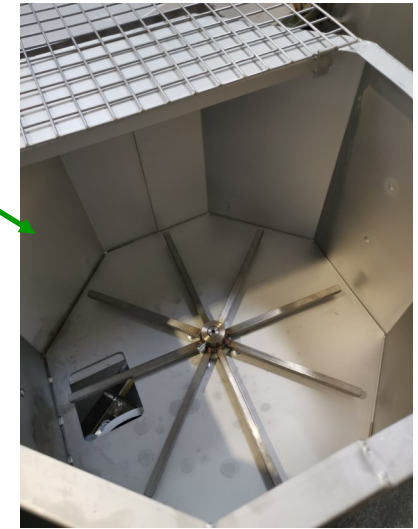

The hopper locks in place for safety & vibration reduction

Adjustable feed gate (stainless steel) for easy and precise dosing of the material to the mill head



Custom quick change, anti slip dies reduces down time and increases profitability. Can be made of steel or stainless steel.



All systems come with integrated water dosing pump

Mill head and rollers have premium grade bearings for long life and reduction of operating costs.

Lockable industrial castors for easy portability and cleaning

Premium quality gearboxes (Bonfiglioli) and low service factor 3 phase electric motors for years of use

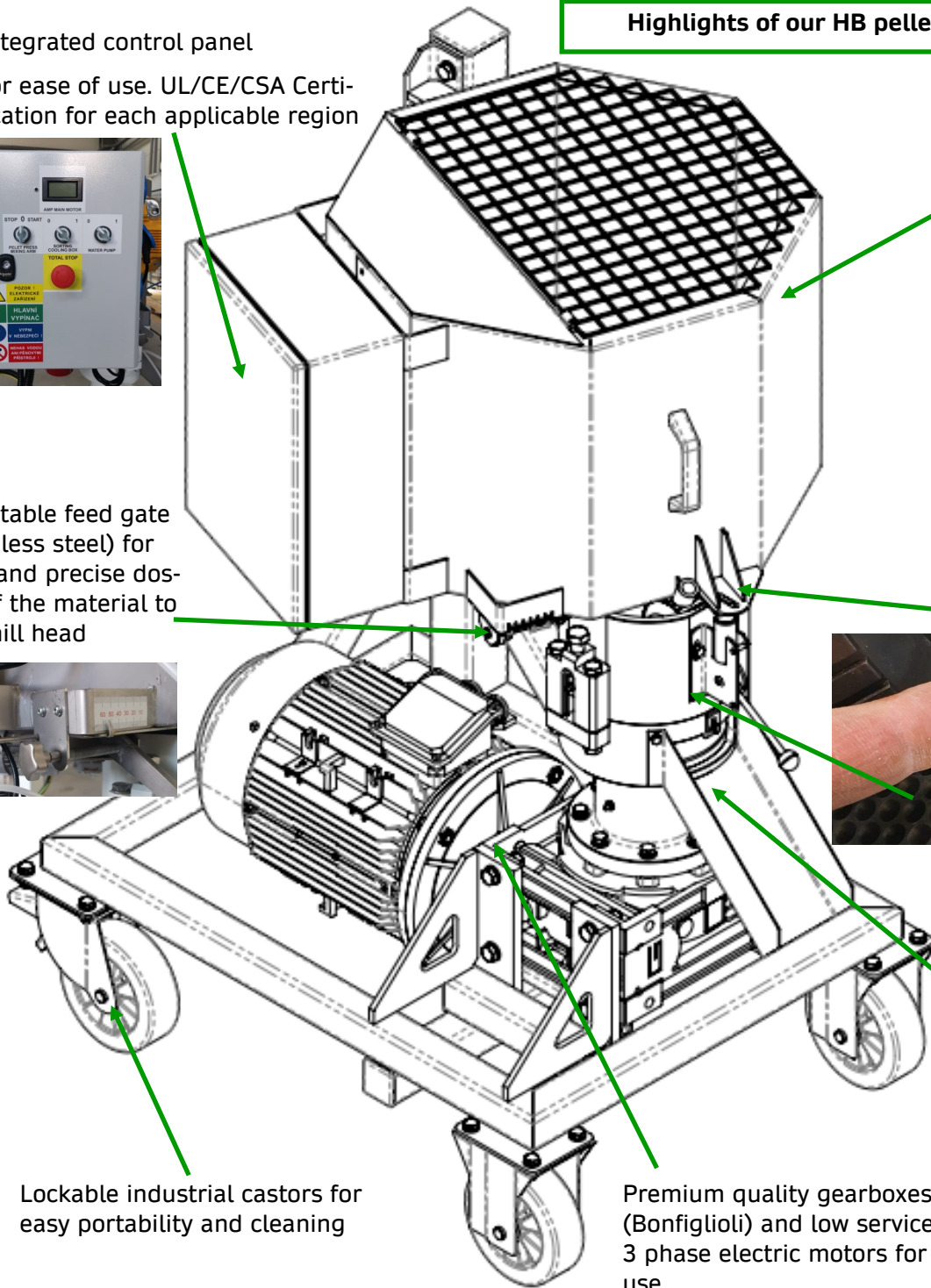

Accessories for our small pellet mill line



Stainless steel vibrating pellet cleaner with plexiglass hood for operator observation 7.5kw shown



Hammer mills and shredders: Built with carbide blades and heavy duty hammers, dust control built into each unit.



1.2 or 2.5 m3 fully stainless steel hopper, for larger scale grinding and pelleting. The hopper includes a gear driven sweep arm and feed chute for easy dosing of the pellet mill hopper.

Easy access panel on the side for cleaning and maintenance piping/fan and dust control are included from the hammer mill.

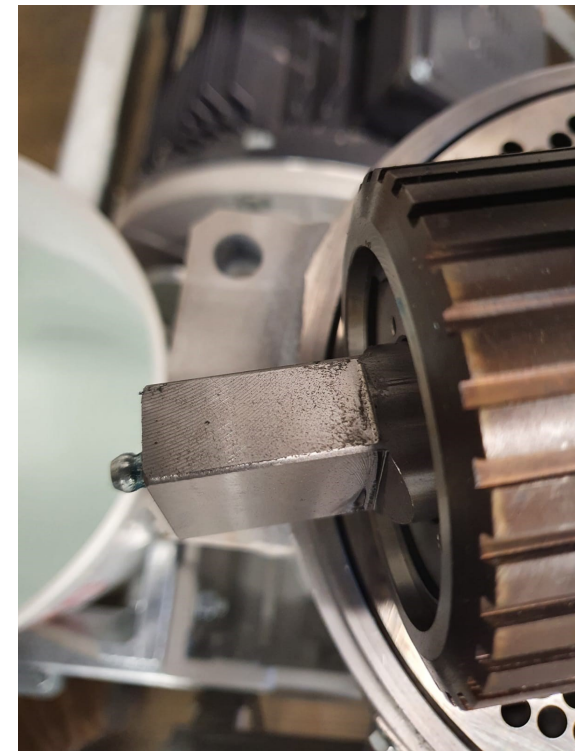
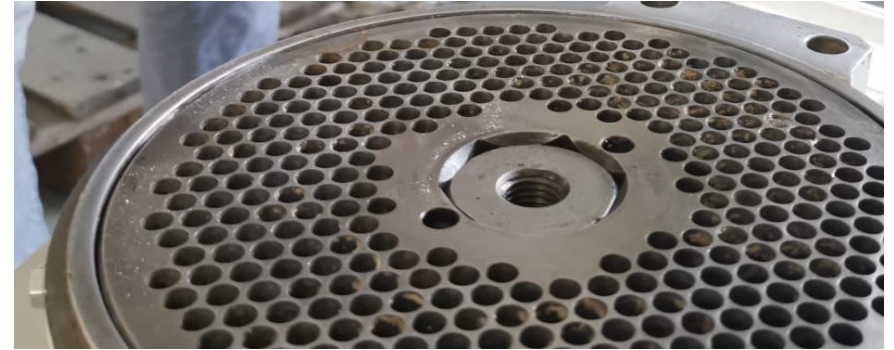

Precision engineered systems for longevity.

- * All our units come with a 2 year manufactures warranty
- * We build all the systems ourselves (factory tours available)
- * Premium CNC machined parts reduces wear and vibration
- * Built to last, long life bearings and stainless steel or galvanized frames
- * Fully stainless options available for food applications
- * Over 40 different die combinations for specific materials
- * 25 years of pelleting experience
- * Simple to operate and maintain
- * 7 days a week phone and internet support